



快速入门指南  
Quick Start Guide

## About FiiO

"Jade Audio" is a subsidiary brand of FiiO Electronics Technology Co., Ltd. It is a stylish, technological and youth-oriented brand aiming to provide high-quality yet cost-effective audio products with an excellent listening experience for the younger generation all around the world. The entity's Chinese name is derived from "翡声" (Fei Sheng), meaning "the sound of Jade". The name "Jade Audio" conveys our mission towards providing consumers with a crisp and pleasant listening experience while maintaining audio fidelity.

FiiO is a high-tech enterprise focusing on researching and developing portable music products, with current main products being hi-res music players, portable headphone DAC/Amps and headphones/earphones. Including a core team with nearly 30 years of R&D experience in audio products development, FiiO is specialized in self-research and development, and sells FiiO-branded products through sales agents worldwide. By virtue of high quality products and great customer service, FiiO enjoys a high reputation in the industry and has received countless well-known awards.

FiiO is committed to its brand proposition "Born for Music" and ceaselessly pursues perfection in product design and manufacturing to supply users with the best audio products at the best prices.

## Buttons and Ports Labeled

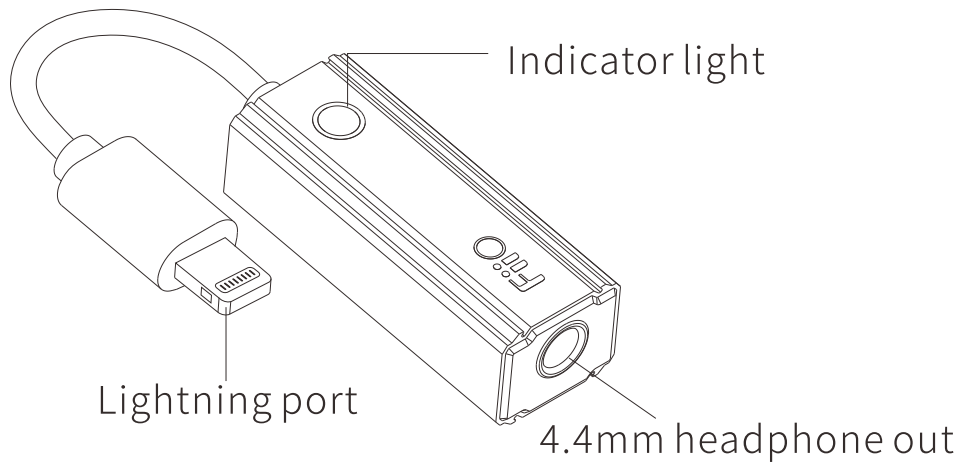
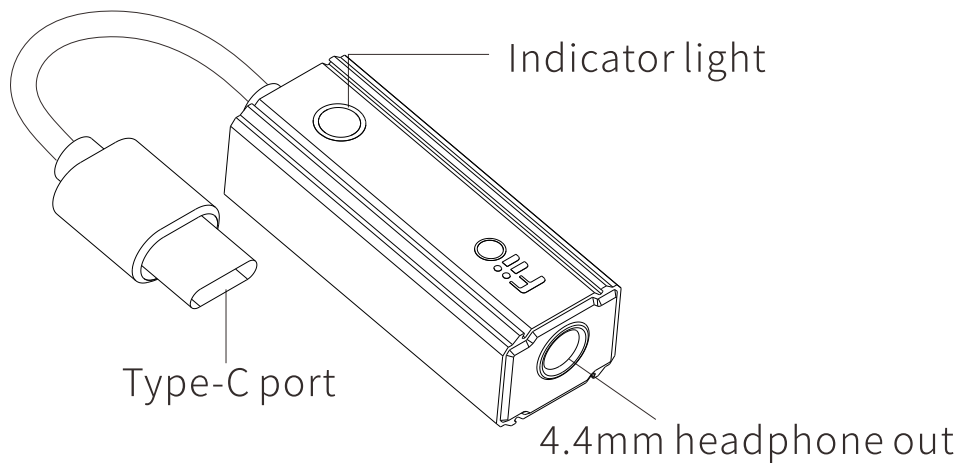

## Operating Instructions

1. Use a USB Type-C or Lightning cable to directly connect the KA2 to devices like a mobile phone, tablet PC, etc.
  - There may be a compatibility issue for some devices due to system and hardware differences.
  - The OTG function of some mobile phones may need to be enabled manually in order to use the KA2 normally.
2. It is driver-free when connected to a PC running Windows 10.18.3 or above and Mac OS. (USB DAC driver is required when connected to a PC running below Windows 10.18.3.)  
Driver download link: <https://www.fiiO.com/supports>
  - The USB-A adapter included in the accessory is designed for the USB-A port.
  - Please set the sound output to "KA2" or "K series" when playing on the computer.

3. When working in the Exclusive USB Audio Access Mode, the volume adjustment of some devices may not work. Please make sure the volume is appropriate before wearing headphones.

4. The indicator light of the KA2 can display the sampling rate of the current playing song, listed as follows:

Indicator light	PCM $\leq$ 48kHz	Blue light on
	PCM $>$ 48kHz	Yellow-green light on
	DSD	Green light on

## Notes and Precautions

1. If the KA2 is charged through the USB of mobile phones or computers, it will consume their power.
2. Since the KA2 features a high-performance DAC/Amp chip, it is normal that heating would occur during use.
3. Please adjust the volume to a suitable level before wearing headphones so as to protect your hearing.
4. Please do not wear headphones when plugging in or unplugging the headphones in case there may be a sudden impulse noise damaging your hearing.
5. Please do not repair or disassemble the product on your own and please keep it away from water.
6. You may be unable to hear the sounds around you when wearing headphones. For your safety, it's not recommended to use headphones in dangerous environments.

## Authenticity Checking

- ① Scratch off the coating to get a 20-bit security code.
- ② Go to FiiO official website at [www.fii.com](http://www.fii.com). Click the 'Check Authenticity' icon in the upper-right corner, and then enter the 20-bit security code and 4-bit verification code. You will get the checking result after clicking the 'query' icon.
- ③ Checking result:
  - A. The security code entered proves the product is authentic.

The product you purchased is an authentic product from Guangzhou FiiO Electronics Technology Co., Ltd. Thanks for your support!

B. The security code entered proves the product is not authentic.

The product you purchased is not an authentic product from Guangzhou FiiO Electronics Technology Co., Ltd.

## Warranty Terms and Conditions

Product Types		Term of Service
Main body		One month of guarantee for replacement; one year of free maintenance
Accessories except for the main body (subject to the official list)	Accessories	N/A
	Package materials (fragile parts like the packing box)	N/A
Notes: 1. The above guarantees start from the issue date of the invoice/receipt. 2. These warranty terms are for reference only. For specific details, please refer to the warranty terms of our local sales agents.		

Guangzhou Jade Audio Technology Co., Ltd / Guangzhou FiiO Electronics Technology Co., Ltd reserve the final interpretation and amendment for the above warranty terms and conditions.

The warranty is null and void under the following circumstances.

--Defects or damage caused by improper operations such as vibrating, bumping, falling to the ground, buckling, tearing, excessive pulling.

--Defects or damage caused by disassembly of the product by the user or unauthorized repair personnel.

--Defects or damage for being put in humid environments, high-intensity magnetic fields or soaked into water.

--Defects or damage caused by natural disasters.

--Unable to provide valid proofs of purchase.

Note: Man-made damage is determined by the Jade Audio or FiiO's maintenance personnel.

## Procedures of After-Sales Service

- ① Please contact the local dealer first once you find problems with the device from Jade Audio or FiiO. If they refuse to give related after-sales service, please give feedback to Jade Audio Support or FiiO Support by sending an email to [support@jadeaudio.com](mailto:support@jadeaudio.com) or [support@fiio.com](mailto:support@fiio.com). We would handle it properly to ensure customers' satisfaction.
- ② For repair service, you are supposed to send the defective product to Jade Audio or FiiO with freight paid. After being repaired, the device will be sent back to you with the freight paid by us.
- ③ It is highly suggested to buy a product from our local authorized sales agents to get better, faster before- and after-sales service.
- ④ Please do not maintain or dismantle the product on your own and please keep it away from water.
- ⑤ For abnormal working issues or any further questions, please visit our official website->Support to get related information or send an email to [support@jadeaudio.com](mailto:support@jadeaudio.com) or [support@fiio.com](mailto:support@fiio.com) for consultation.

Note: Due to continuous improvement, each specification and design is subject to change at any time without further notice.

## Contact Information for After-Sales Service

E-mail: [support@jadeaudio.com](mailto:support@jadeaudio.com); [support@fiio.com](mailto:support@fiio.com)

Web: <http://www.jadeaudio.com>; <https://www.fiio.com>

Facebook: <https://www.facebook.com/JadeAudio.Co>

<https://www.facebook.com/FIIOAUDIO>

## To Learn More

To learn more about the product, please visit our website: [www.fiio.com/supports](http://www.fiio.com/supports).

Hereby, Guangzhou FiiO Electronics Technology Co., Ltd declares that this device is in compliance with Directive 2014/30/EU. The full text of the EU declaration of conformity is available at: [www.fiio.com/doc](http://www.fiio.com/doc)



## WEEE Directive & Product Disposal



At the end of its serviceable life, this product should not be handed as household or general waste. It should be handed over to the applicable collection point for the recycling of electrical and electronic equipment, or returned to the supplier for disposal.

## Internal/Supplied Batteries

This symbol on the battery indicates that the battery is to be collected separately. This battery is designed for separate collection at an appropriate collection point.

This equipment has been tested and found to comply with the limits for a Class B digital device, pursuant to part 15 of the FCC Rules. These limits are designed to provide reasonable protection against harmful interference in a residential installation. This equipment generates, uses and can radiate radio frequency energy and, if not installed and used in accordance with the instructions, may cause harmful interference to radio communications. However, there is no guarantee that interference will not occur in a particular installation. If this equipment does cause harmful interference to radio or television reception, which can be determined by turning the equipment off and on, the user is encouraged to try to correct the interference by one or more of the following measures:

- Reorient or relocate the receiving antenna.
- Increase the separation between the equipment and receiver.
- Connect the equipment into an outlet on a circuit different from that to which the receiver is connected.
- Consult the dealer or an experienced radio/TV technician for help.

This device complies with part 15 of the FCC Rules. Operation is subject to the following two conditions:

- (1) This device may not cause harmful interference, and
- (2) this device must accept any interference received, including interference that may cause undesired operation.